

KOMATSU®

PC490LC-10

Tier 4 Interim Engine
Material Handler

PC490LC

Material Handler

NET HORSEPOWER

359 HP @ 1900rpm
268 kW @ 1900rpm

OPERATING WEIGHT

126,530–128,940 lb
57410–58500 kg

REACH

54'–55'
16.5–16.8 m



PHOTOS MAY INCLUDE OPTIONAL EQUIPMENT

Material Handler Features:

Choice of 2-piece front 16.8 m 55' or 3-piece front 16.5 m 54' with underslung hydraulic cylinders, boom/arm holding valves and boom/arm hose burst valves

Optimized Hydraulic System (OHS) valves to adjust work equipment speed for a specific job

Operator control levers for grapple open-close-rotate and magnet charge-discharge

25 kw generator (Baldor) hydraulically driven with controller mounted in the cab riser

Auxiliary hydraulic pump to drive generator or other attachment

Plumbing for grapple attachment

Electrical cable for magnet attachment and magnet connecting link

Carbody widened and reinforced, retractable for shipping

Additional counterweight with reinforced revolving frame

78" cab riser, manual tilt, with front window guard

Large slip resistant platform with steps and handrails for easy cab access

Centralized grease points at boom foot

Parts and operator manuals

For Use In:**Scrap Processing**

- Stockpiling of recycled materials
- Transfer station material feeding

Bulk Material Handling

- Coal, coke, and ore
- Sand and gravel
- Grain



PC490LC-10

Tier 4 Interim Engine
Material Handler

NET HORSEPOWER
359 HP @ 1900rpm
268 kW @ 1900rpm

OPERATING WEIGHT
126,530–128,940 lb
57410–58500 kg

REACH
54'–55'
16.5–16.8 m

Komatsu Hydraulic Excavators offer great overall value, reliability and versatility. Engines, pumps, valves, cylinders and all other major components are designed to work together to maximize efficiency and productivity. Now add the Material Handling package which is integrated into the base excavator and you have a purpose-built machine that maximizes lift capacity, speed and balance in all scrap handling or bulk material handling applications.

A powerful Komatsu SAA6D125E-6-A engine provides a net output of 268 kW **359 HP**. This engine is EPA Tier 4 Interim and EU stage 3B emissions certified.

Komatsu Variable Geometry Turbocharger (KVGT) uses a hydraulic actuator to provide optimum air flow under all speed and load conditions.

Komatsu Diesel Particulate Filter (KDPF) captures 90% of particulate matter and provides automatic regeneration that does not interfere with daily operation.

Large displacement high efficiency pumps provide higher flow output at a lower engine speed and efficient operation.

Two boom mode settings provide power mode for maximum lifting force or smooth mode for precise positioning operations.

Komatsu Closed Center Load Sensing (CLSS) hydraulic system provides quick response and smooth operation to maximize productivity.

Rearview monitoring system (standard)

Large LCD color monitor panel:

- 7" high resolution screen
- Provides "Eco-Guidance" for fuel efficient operation
- Enhanced attachment control

Enhanced working modes are designed to match engine speed, pump delivery, and system pressure to the application.

Enhanced working environment

- High back, heated, and air suspension operator seat
- Integrated ROPS cab design (ISO 12117-2)
- Cab meets ISO Level 1 Operator Protective Guard (OPG) top guard (ISO 10262)

Equipment Management Monitoring System (EMMS)

continuously monitors machine operation and vital systems to identify machine issues and assist with troubleshooting.



Komatsu designed and manufactured components

Hydraulically driven variable speed fan reduces parasitic load on the engine to improve fuel consumption and can be reversed to simplify cooler maintenance.

Guardrails (standard) located on the machine upper structure provide a convenient work area in front of the engine.

Battery disconnect switch allows a technician to disconnect the power supply before servicing the machine.

Heavy duty boom design with box section construction provides increased strength and reliability.

KOMTRAX®

Komtrax equipped machines can send location, SMR and operation maps to a secure website utilizing wireless technology. Machines also relay error codes, cautions, maintenance items, fuel levels, and much more.



Material Handling Fronts

Material handling fronts are offered in 2-piece design 16.8 m **55 ft** reach and 3-piece design 16.5 m **54 ft** reach. Fabricated by Young Corporation, both fronts incorporate reinforced box section design using high strength alloy steel to minimize weight while maximizing strength and durability.

Large diameter hydraulic cylinders are hydraulically cushioned and utilize spherical ball bushings to eliminate side stress.



2-piece front is available for the majority of material handling applications.

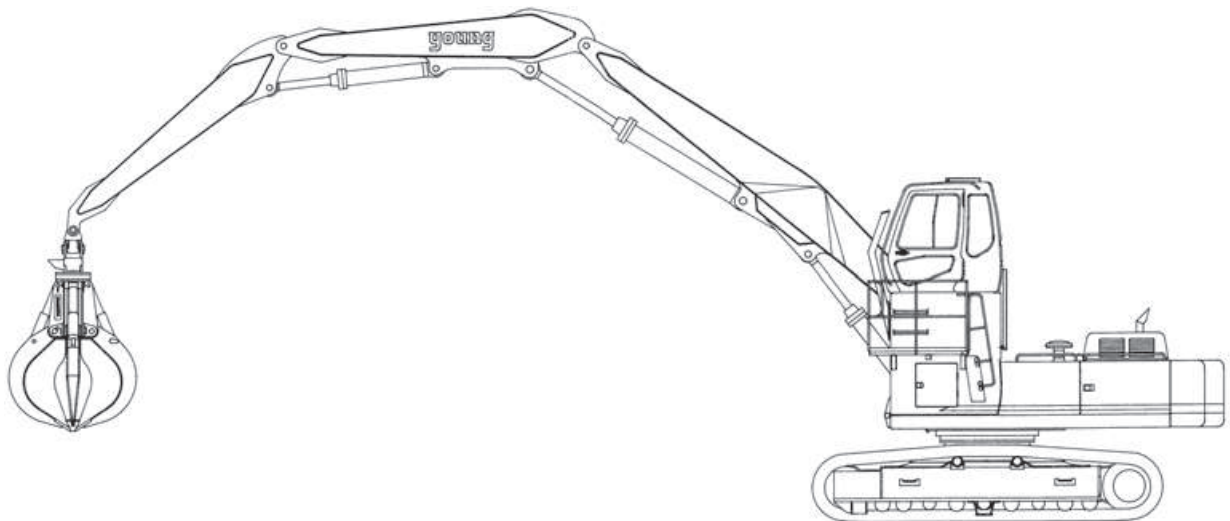

3-piece front is available for larger vertical working range when the load is close to the machine.

Operator Control Levers

Operator control levers have low effort multi-function buttons for grapple open-close-rotate and magnet charge-discharge.



Generator Monitor

Generator monitor with on-off switch is conveniently located in the line of site between operator and work equipment.



Optimized Hydraulic System (OHS)

Optimized Hydraulic System (OHS) valves mounted inside the cab riser can be easily adjusted to optimize work equipment speed (boom raise, arm in, grapple/bucket open-close) for a specific job and provide hydraulic cushion.



Dedicated Auxiliary Pump

Dedicated auxiliary pump mounted to the back of main hydraulic pump drives the 25 KW generator located in the cab riser.



Baldor Generator and Hubble Controller

The Baldor generator and Hubble controller have proven performance and reliability in the scrap recycling industry. Magnet discharge time is fast and clean and is adjustable for different material weights. High thermal capacity varistor limits voltage spikes and provides essential circuit protection. Amp meter, voltmeter, and generator tachometer help monitor the 230 volt system.



Carbody and Variable Track Gauge

Carbody is widened by 24" to obtain 11'6" track gauge for stability. Structure is reinforced using heavy duty high strength steel plates. Variable track gauge is retractable to under 12' wide for shipping.



Centralized Grease Points

Centralized grease points are located at boom foot to facilitate daily maintenance.



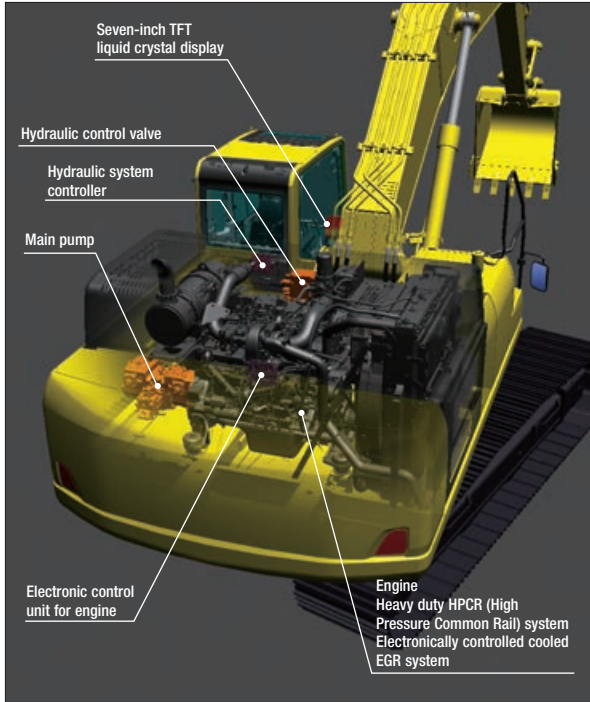

Advanced Electronic Control System

The engine control system has been upgraded to effectively manage the air flow rate, EGR gas flow rate, fuel injection parameters, and aftertreatment functions. The new control system also provides enhanced diagnostic capabilities.

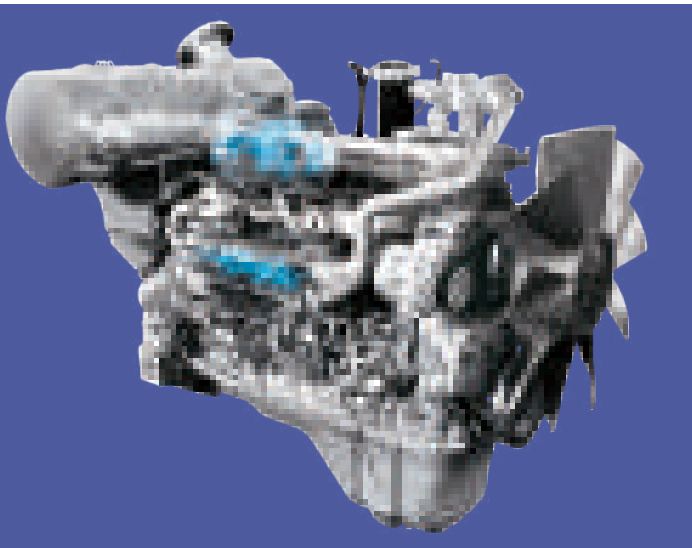

Environment-Friendly Engine

The Komatsu SAA6D125E-6-A engine is EPA Tier 4 Interim and EU Stage 3B emissions certified and provides exceptional performance while reducing fuel consumption. Based on Komatsu proprietary technologies developed over many years, this new diesel engine reduces exhaust gas particulate matter (PM) by more than 90% and nitrogen oxides (NOx) by more than 45% when compared to Tier 3 levels.

Through the in-house development and production of engines, electronics, and hydraulic components, Komatsu has achieved great advancements in technology, providing high levels of performance and efficiency in virtually all applications.

Komatsu Diesel Particulate Filter (KDPF)

Komatsu has developed a high efficiency diesel particulate filter that captures more than 90% of particulate matter. Both passive and active regeneration are automatically initiated by the engine controller depending on the soot level of the KDPF. A special oxidation catalyst with a fuel injection system is used to oxidize and remove particulate matter while the machine is running so the regeneration process will not interfere with daily operation.

The operator can also initiate regeneration manually or disable regeneration depending on the work environment.

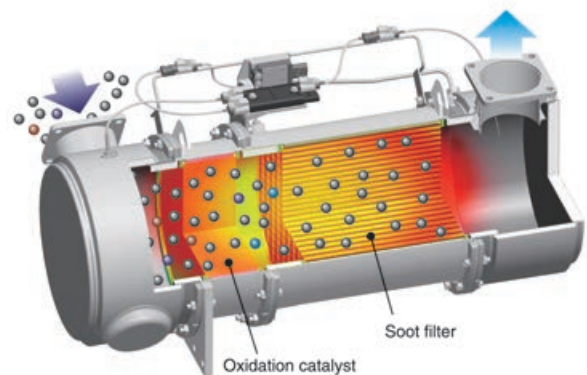

Komatsu Variable Geometry Turbocharger (KVTG)

Using Komatsu proprietary technology, a newly designed variable geometry turbocharger with a hydraulic actuator is used to manage and deliver optimum air flow to the combustion chamber under all speed and load conditions. The robust hydraulic actuator provides power and precision, resulting in cleaner exhaust gas and improved fuel economy while maintaining performance.

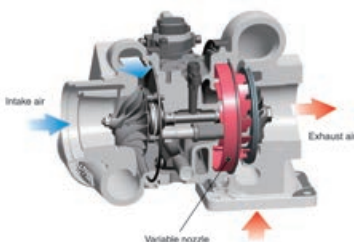

Closed Crankcase Ventilation (CCV)

Crankcase emissions (blow-by gas) are passed through a CCV filter. The CCV filter traps oil mist which is returned back to the crankcase while the gas, which is almost oil mist free, is fed back to the air intake.



Redesigned Combustion Chamber

The combustion chamber located at the top of the engine piston has a new shape designed to improve combustion and further reduce NOx, PM, fuel consumption, and noise levels.

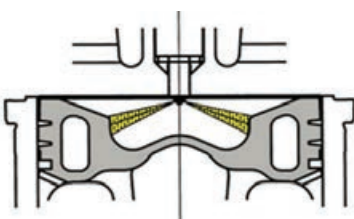

Low Operational Noise

The PC490LC-10 provides low noise operation using a low noise engine and methods that reduce noise at the source such as sound absorbing materials.

Cooled Exhaust Gas Recirculation (EGR)

Cooled EGR, a technology that has been well proven in Komatsu Tier 3 engines, reduces NOx emissions to meet Tier 4 levels. The hydraulically actuated EGR system has increased capacity and uses larger and more robust components to ensure reliability for demanding work conditions.

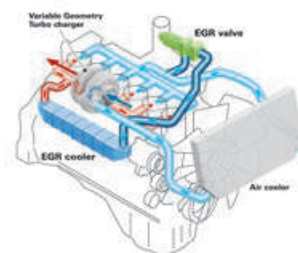

Heavy Duty High Pressure Common Rail (HPCR) Fuel Injection System

The heavy duty HPCR system is electronically controlled to deliver a precise quantity of pressurized fuel into the combustion chamber using multiple injection events to achieve complete fuel burn and reduce exhaust gas emissions. Fuel injector reliability has been improved by using ultra-hard wear resistant materials.

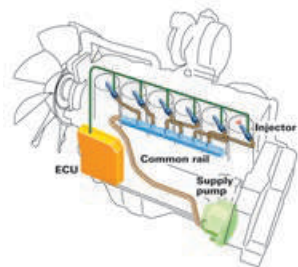

Hydraulic Variable Speed Fan

The electronic control system sets the revolution speed of the cooling fan according to the coolant, hydraulic oil, and ambient temperature; effectively uses the engine output to reduce wasteful fuel consumption; and reduces noise during low-speed fan revolution.



Efficient Hydraulic System

The PC490LC-10 uses a Closed Center Load Sensing (CLSS) hydraulic system that improves fuel efficiency and provides quick response to the operator's demands.

The PC490LC-10 also introduces new technology to enhance the engine and hydraulic pump control. This total control system matches the engine and hydraulics at the most efficient point under any load condition. There have also been improvements in the main valve and hydraulic circuit to reduce hydraulic loss, resulting in higher efficiency and lower fuel consumption.

Reduced Up To 5% Fuel consumption

vs PC450LC-8
Based on typical work pattern collected via KOMTRAX

Large Displacement High Efficiency Pump

Pump displacement has been increased, providing increased flow output as well as operation at the most efficient engine speed.

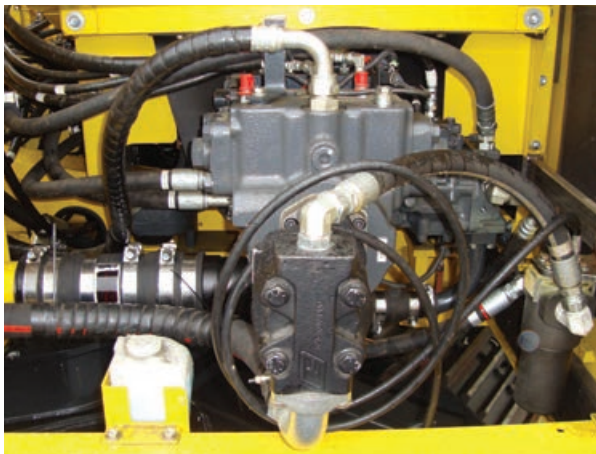

Idling Caution

To reduce unnecessary fuel consumption, an idling caution is displayed on the monitor if the engine idles for 5 minutes or more.



Working Mode Selection

The PC490LC-10 excavator is equipped with five working modes (P, E, B, ATT/P and ATT/E). Each mode is designed to match engine speed, pump flow, and system pressure to the application. The PC490LC-10 features a new mode (ATT/E) which allows operators to run attachments while in Economy mode.

Working Mode	Application	Advantage
P	Power mode	<ul style="list-style-type: none"> •Maximum production/power •Fast cycle times
E	Economy mode	<ul style="list-style-type: none"> •Good cycle times •Better fuel economy
B	Breaker mode	<ul style="list-style-type: none"> •Optimum engine rpm, hydraulic flow
ATT/P	Attachment Power mode	<ul style="list-style-type: none"> •Optimum engine rpm, hydraulic flow, 2-way •Power mode
ATT/E	Attachment Economy mode	<ul style="list-style-type: none"> •Optimum engine rpm, hydraulic flow, 2-way •Economy mode

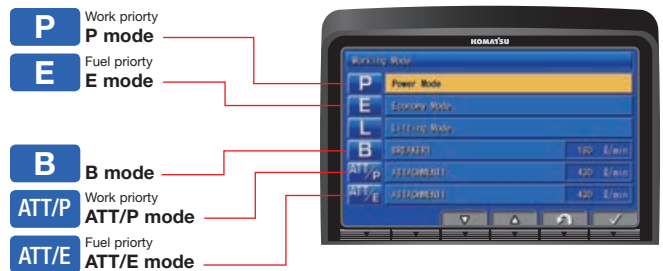

Eco-Gauge Assists with Energy Saving Operations

The Eco-gauge and new fuel consumption gauge are viewed on the right side of the color monitor and assist the operator in maintaining low fuel consumption and environment friendly operation.



GENERAL FEATURES

ROPS Cab Design

The PC490LC-10 is equipped with an integrated ROPS cab as standard equipment. The cab also meets OPG Top Guard Level 1 requirements.



Guardrails

Guardrails have been added on the upper structure of the machine. This provides additional convenience during engine service.



Thermal and Fan Guards

Thermal and fan guards are placed around high temperature parts of the engine and fan drive.

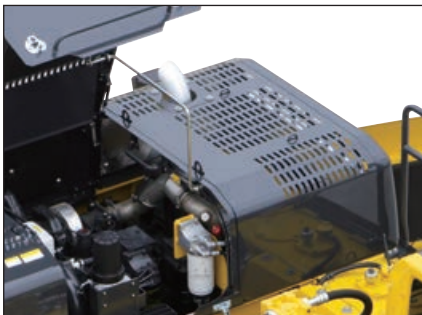

Rear-view Monitoring System (standard)

On the large LCD color monitor the operator can view the image from one camera that will display areas directly behind the machine. An optional 2-camera system is available.



Rear view image on monitor

Seat Belt Caution Indicator

A warning indicator on the monitor appears when the seat belt is not engaged.



Lock Lever

When the lock lever is placed in the lock position, all hydraulic controls (travel, swing, boom, arm, and bucket) are inoperable.



Secondary Engine Shutdown Switch

A new secondary switch has been added to shutdown the engine.



Slip Resistant Plates

Durable slip resistant plates maintain excellent foot traction



Komatsu Designed Components

All of the major machine components such as the engine, hydraulic pumps, hydraulic motors, and control valves are exclusively designed and manufactured by Komatsu.

High Efficiency Fuel Filter

A new high efficiency dual element fuel filter improves fuel system reliability.



Fuel filter Fuel pre-filter (with water separator)

Equipped with a Fuel Pre-filter (With Water Separator)

A fuel pre-filter removes water and contaminants in the fuel to increase reliability. For convenience, the fuel pre-filter has a built in priming pump.

O-Ring Face Seals

Flat face-to-face O-ring seals are used to securely seal hydraulic hose connections.



Durable Frame Structure

The revolving frame, center frame, and undercarriage are designed using the most advanced three dimensional CAD and FEM analysis technology.

DT-type Connectors

Sealed DT-type connectors provide high reliability, water resistance, and dust resistance.

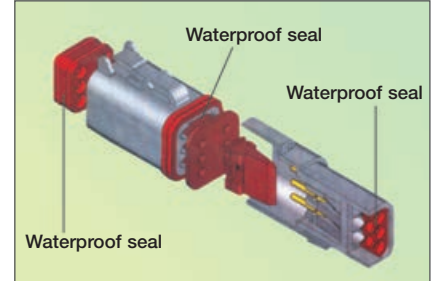

Grease Sealed Track

The PC490LC-10 uses grease sealed tracks for extended undercarriage life.

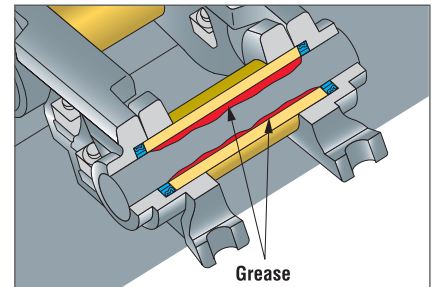

Highly Reliable Electronic Devices

Exclusively designed electronic devices have passed severe testing.

- Controllers
- Sensors
- Connectors
- Heat Resistant Wiring

A reinforced revolving frame and undercarriage design provides additional strength and reliability.



1 Counterweight: Heavier for increased lift capacity
12317 kg **27,150 lb**

2 Swing circle: Reinforced
Increased swing bearing capacity
(Increased diameter)

3 Track shoe: Reinforced
Increased link height and tread width
Diameter of pin and bushing is increased
Shoe thickness and bolt strength is increased

4 Final drive
Track frame bolt and sprocket mounting bolt have higher axial tension

5 Sprocket
Material strength is increased
New tooth shape design

6 Center frame: Reinforced

7 Carrier rollers and idler: Reinforced
Increased tread width

8 Crawler frame: Reinforced

9 Revolving frame: Reinforced

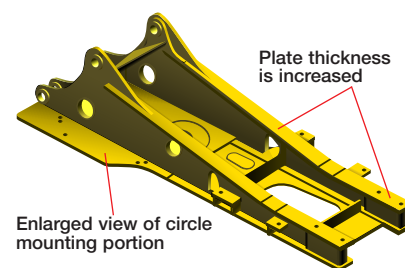

Enlarged view of circle mounting portion

Bottom plate thickness is increased for Material Handler



Newly Designed Wide Spacious Cab

The newly designed wide spacious cab features a high back, fully adjustable seat with a reclining backrest. The console and seat have an integrated design so that they move together and provide additional comfort for the operator.

The new higher capacity operator seat has been enhanced to provide more comfort.

- Heated
- Air Suspension
- Integrated Seat
- Console Mounted Arm Rests



Low Cab Noise

The new cab design is highly rigid and has excellent sound absorption ability. By improving noise source reduction and by using a low noise engine, hydraulic equipment, and air conditioner, this machine is able to generate low noise levels similar to that of a modern automobile.

Automatic Air Conditioner

The automatic air conditioner allows the operator to easily and precisely set the cab atmosphere using the large LCD color monitor panel. The bi-level control function improves air flow and keeps the inside of the cab comfortable throughout the year.

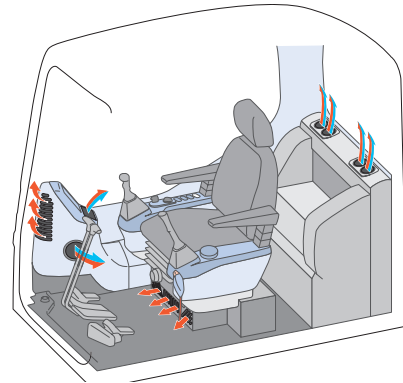

Pressurized Cab

The air conditioner, air filter, and a higher internal cab air pressure minimize the amount of external dust that enters the cab.

Low Vibration with Viscous Cab Mounts

The PC490LC-10 uses viscous mounts for the cab that incorporate a longer stroke and the addition of a spring. The cab damper mounting combined with a high rigidity deck reduces vibration at the operator's seat.

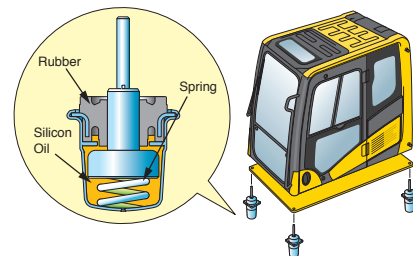

Auxiliary Input (MP3 Jack)

By connecting an auxiliary device such as an MP3 player to the auxiliary input, the operator can hear the sound through the speakers installed in the cab.





Large High Resolution LCD Monitor Panel

A new large, user-friendly, high resolution LCD color monitor enables accurate and smooth work. Screen visibility and resolution are further improved compared to the previous LCD monitor panel. The switches and function keys are easy to operate and provide simple navigation through the monitor screens.

Data is displayed in 25 languages to support operators around the world.

Indicators

- | | |
|----------------------------------|-----------------------------------|
| 1 Auto-decelerator | 5 Hydraulic oil temperature gauge |
| 2 Working mode | 6 Fuel gauge |
| 3 Travel speed | 7 Eco-gauge |
| 4 Engine water temperature gauge | 8 Fuel consumption gauge |
| | 9 Function switches menu |

Basic operation switches

- | | |
|-------------------------|---------------------|
| 1 Auto-decelerator | 4 Buzzer cancel |
| 2 Working mode selector | 5 Wiper |
| 3 Traveling selector | 6 Windshield washer |

Operational "ECO" Guidance

The monitor panel provides operational advice to the operator to help improve machine efficiency and lower fuel consumption. The operator can access the ECO guidance menu to check the Operation Records, Eco Guidance Records, and Average Fuel Consumption Logs.



ECO Guidance



ECO Guidance menu

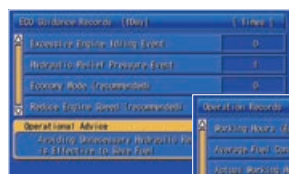

ECO Guidance Records

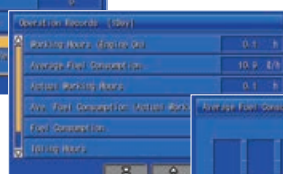

Operation Records



Average Fuel Consumption Logs

Improved Attachment Control

The PC490LC-10 is capable of storing up to ten different attachments in the new monitor panel. The name of each attachment can be changed for better tool management. Hydraulic flow rates can be easily adjusted for one-way and two-way flow attachments.

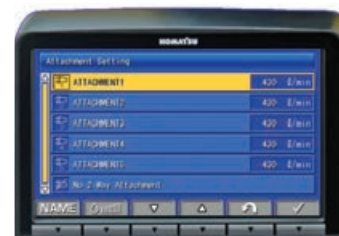

Attachment Setting Screen



Attachment Flow Screen

Reversible Cooling Fan

The reverse rotation function of the hydraulic driven fan simplifies cooler maintenance.



KDPF Regeneration Notification

The LCD color monitor panel provides the operator with the status of the KDPF regeneration, without interfering with daily operation.

When the machine initiates active regeneration an icon will appear to notify the operator.



Battery Disconnect Switch

A standard battery disconnect switch allows a technician to disconnect the power supply and lock out before servicing the machine.



Manual Stationary Regeneration

Under most conditions, active regeneration will occur automatically with no effect on machine operation. In case the operator needs to disable active regeneration or initiate a manual stationary regeneration, this can be easily accomplished through the monitor panel.

A soot level indicator is displayed to show how much soot is trapped in the KDPF.

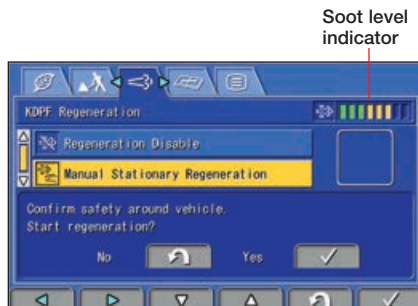

Long Life Oils, Filters

High performance filters are used in the hydraulic circuit and engine. By increasing the oil and filter replacement intervals, maintenance costs can be significantly reduced.



Hydraulic oil filter (Eco-white element)

Engine oil & Engine oil filter	every 500 hours
Hydraulic oil	every 5000 hours
Hydraulic oil filter	every 1000 hours

Equipped with Eco-drain Valve

Minimizes ground contamination due to oil leakage when replacing the engine oil.



Electric Priming Pump

Bleeding air from the fuel system is easily accomplished with the new electric priming pump.

Equipment Management Monitoring System (EMMS)

The PC490LC-10 features an advanced diagnostic system that continuously monitors the machine's vital systems. EMMS tracks maintenance items, provides advanced troubleshooting tools, reduces diagnostic times, and displays error codes.

Through continuous monitoring, the EMMS helps identify issues before they become worse and allows the operator to concentrate on the work at hand.

Abnormalities Display with Code

When an abnormality occurs an error code is displayed on the monitor. When an important code is displayed, a caution lamp blinks and warning buzzer sounds to alert the operator to take action.

The monitor also stores a record of abnormalities for more effective troubleshooting.



Advanced Monitoring System

The monitor provides advanced monitoring diagnostics to assist with troubleshooting and reduce costly downtime.

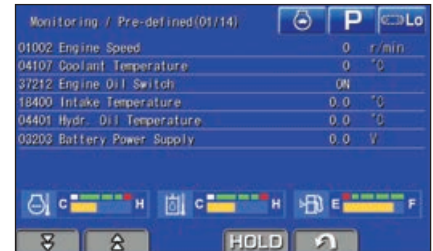

Maintenance Tracking

When the machine approaches or exceeds the oil and filter replacement interval, the monitor panel will display lights to inform the operator.

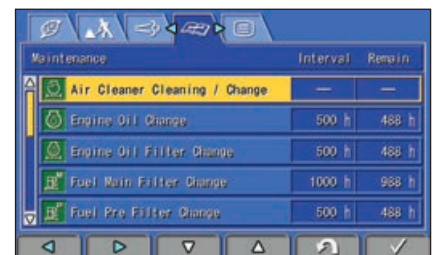

KOMATSU PARTS & SERVICE SUPPORT



Komatsu is an industry leader in building reliable and technologically advanced machines. It is only fitting that we would provide superior Product Support. Komatsu and its distributors are focused on providing their customers unparalleled Product Support throughout the entire lifecycle of the machine. It's called Komatsu CARE.

Komatsu CARE – Complimentary Scheduled Maintenance

Komatsu remains focused on lowering the customer's ownership costs by engineering machines with increased fuel efficiency and productivity. In addition, one Komatsu CARE program aimed at further reducing your owning and operating costs is Complimentary Scheduled Maintenance. Komatsu machine owners can now rely on their Komatsu Distributor to perform the preventative maintenance on their Komatsu Tier 4 machines.

- Complimentary scheduled maintenance for the earlier of 3 years or 2,000 hours is standard on all Komatsu Tier 4 construction machines and is available at all distributors in the U.S. and Canada.
- Service is performed by factory certified technicians using only Komatsu Genuine parts and fluids
- Significantly lowers your cost of ownership while maintaining high equipment uptime and reliability
- Increases resale value and provides detailed maintenance records

Komatsu CARE – Extended Coverage

Komatsu equipment is built to withstand harsh operating environments, but our Extended Coverage can provide further peace of mind by protecting customers from unplanned expenses and impacts in cash flow. Purchasing Komatsu CARE's Extended Coverage locks-in the cost of covered parts and labor for the extended warranty period and helps to turn these variable expenses into a fixed cost.

- No Stop Loss or Loss Limits imposed, regardless of the coverage type or repair expense
- Any combination of months and hours out to five years and 10,000 engine hours – KOWA kits included
- Coverage premium can be rolled into the machine financing at time of sale or purchased any time before the expiration of the machine's standard warranty
- Coverage is fully transferable and honored by all Komatsu distributors throughout the U.S. and Canada

Komatsu CARE – Total CARE

Total CARE combines the benefits of the Komatsu CARE Scheduled Maintenance and Extended Coverage programs on your Tier 4 machine. This ensures the use of Komatsu genuine parts and fluids during regular maintenance intervals as well as highly skilled and efficient technicians to perform any other warranty repair work that might be necessary to keep your Komatsu equipment running like new.

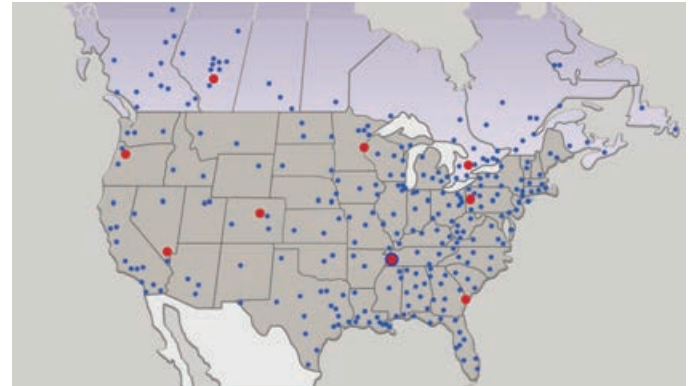

Komatsu Parts Support

Because downtime can be costly, Komatsu maintains a strategic distribution network throughout the U.S. and Canada, to ensure superior parts availability and to keep your Komatsu machine up and running.

- Komatsu America has nine Parts Distribution Centers strategically located throughout the U.S. and Canada
- Komatsu America's Parts distribution network is accessible 24/7/365 to fulfill your parts needs
- Komatsu has a distributor network of over 325 locations across the U.S. and Canada
- Online parts ordering available through Komatsu eParts, 24/7/365. (See distributor for details)
- Komatsu offers a full line of factory Remanufactured products with same-as-new warranties at a significant cost reduction:
 1. Complete Engine Assemblies
 2. Transmissions
 3. Torque Converters
 4. Hydraulic components
 5. Starters, Alternators, turbochargers and circuit boards

Komatsu Oil and Wear Analysis (KOWA)

The KOWA program uses independent laboratories across the United States to determine how your machine is performing based on a small sample of oil or other fluid. Just like a doctor will take a blood test to check on your personal health, KOWA allows you to check how your equipment is performing. Used with PM Clinic and PM Tune Up, KOWA is one of your best tools for proactively maintaining your Komatsu equipment and maximizing its availability and performance.

KOWA detects fuel dilution and coolant leaks, identifies contaminants, and measures wear-metals. Your distributor will help you interpret this information so you can identify potential problems and head them off before they lead to major repairs.

For more information of all of the manufacturer sponsored programs mentioned in this brochure, including terms and conditions of the individual programs, please speak with your distributor or go to www.komatsuamerica.com

KOMTRAX EQUIPMENT WORKING ENVIRONMENT MONITORING



KOMTRAX is Komatsu's remote equipment monitoring and management system. KOMTRAX gathers critical machine and operation information and provides it in a user-friendly format so that you can make well-informed decisions. KOMTRAX gives you more control of your equipment and better control of your business!

KOMTRAX comes standard on all new Komatsu machines with complimentary manufacturer communications services throughout the entire ownership period. It is a powerful tool and makes Komatsu machines an even better purchase!

Fleet Optimization

KOMTRAX tells you how your machines and operators are performing. KOMTRAX provides:

- Fuel consumption data and trends, by unit or fleet
- Machine fuel level
- Machine utilization
- Actual working hours/Machine idle hours
- Attachment usage hours
- Machine travel hours
- Machine load analysis
- Operating mode ratios

Location and Asset Management

KOMTRAX tells you where your machines are and can help prevent unauthorized use. KOMTRAX provides:

- GPS location/Operation maps
- Out-of-area and movement alert with location and time
- Engine, nighttime, and calendar lock

Maintenance Management

KOMTRAX monitors the health of your machines and provides critical information so that you, and your distributor, can take proactive maintenance measures and reduce downtime. KOMTRAX provides:

- Service Meter Reading (SMR)
- Cautions/Abnormality codes
- Maintenance replacement notifications

Easy and Flexible Access to Information

With KOMTRAX, information about your machines is available through a convenient, internet-based portal. KOMTRAX provides:

- A user-friendly KOMTRAX website that provides customized access to your machine information
- E-mail and text alerts
- Web dial-up service
- Monthly fleet summary reports

For more information, including terms and conditions of the manufacturer complimentary KOMTRAX communication service, ask your distributor, pick up a KOMTRAX brochure, or go to www.komatsuamerica.com/komtrax.



For construction and compact equipment.



For production and mining class machines.



ENGINE

Model.....Komatsu SAA6D125E-6-A*
 Type.....Water-cooled, 4-cycle, direct injection
 Aspiration.....Turbocharged, aftercooled, cooled EGR
 Number of cylinders..... 6
 Bore.....125 mm **4.92"**
 Stroke.....150 mm **5.91"**
 Piston displacement.....11.04 ltr **674 in³**
 Horsepower:
 SAE J1995.....Gross 270 kW **362 HP**
 ISO 9249 / SAE J1349.....Net 268 kW **359 HP**
 Rated rpm.....1900
 Fan drive method for radiator cooling.....Hydraulic
 Governor.....All-speed control, electronic
 *EPA Tier 4 Interim and EU stage 3B emissions certified



HYDRAULICS

Type.....HydrauMind (Hydraulic Mechanical Intelligence New Design) system, closed-center system with load sensing valves and pressure compensated valves
 Number of selectable working modes..... 6
 Main pump:
 Type.....Variable displacement piston type
 Pumps for.....Boom, arm, bucket, swing, and travel circuits
 Maximum flow.....695 ltr/min **184 gal/min**
 Supply for control circuit.....Self-reducing valve
 Hydraulic motors:
 Travel.....2 x axial piston motors with parking brake
 Swing.....1 x axial piston motor with swing holding brake
 Relief valve setting:
 Implement circuits.....37.3 MPa 380 kg/cm² **5,400 psi**
 Travel circuit.....37.3 MPa 380 kg/cm² **5,400 psi**
 Swing circuit.....27.9 MPa 285 kg/cm² **4,055 psi**
 Pilot circuit.....3.2 MPa 33 kg/cm² **470 psi**
 Hydraulic cylinders:
 (Number of cylinders – bore x stroke x rod diameter)
 Boom.....2–177.8 mm x 1499 mm x 127 mm **7" x 59" x 5"**
 Arm.....1–190.5 mm x 1981 mm x 127 mm **7.5" x 78" x 5"**
 Auxiliary pump for generator:
 Maximum flow.....139 ltr/min **36.7 gal/min**
 Maximum pressure.....24.2 MPa 246 kg/cm² **3,500 psi**
 Mounting flange.....SAE-B, 2 bolt
 Drive spline.....15T-16/32DP



DRIVES AND BRAKES

Steering control.....Two levers with pedals
 Drive method.....Hydrostatic
 Maximum drawbar pull.....329 kN 33560 kg **73,987 lb**
 Gradeability.....70%, 35°
 Maximum travel speed: High.....5.5 km/h **3.4 mph**
 (Auto-Shift) Mid.....4.2 km/h **2.6 mph**
 (Auto-Shift) Low.....3.0 km/h **1.9 mph**
 Service brake.....Hydraulic lock
 Parking brake.....Mechanical disc brake



SWING SYSTEM

Drive method.....Hydrostatic
 Swing reduction.....Planetary gear
 Swing circle lubrication.....Grease-bathed
 Service brake.....Hydraulic lock
 Holding brake/Swing lock.....Mechanical disc brake
 Swing speed.....9.1 rpm
 Swing torque.....13414 kg•m **97,024 ft lbs**



UNDERCARRIAGE

Center frame.....X-frame
 Track frame.....Box-section
 Seal of track.....Sealed track
 Track adjuster.....Hydraulic
 Number of shoes (each side).....49
 Number of carrier rollers (each side).....4
 Number of track rollers (each side).....8



COOLANT & LUBRICANT CAPACITY (REFILLING)

Fuel tank.....650 ltr **172 U.S. gal**
 Coolant.....44 ltr **11.6 U.S. gal**
 Engine.....38 ltr **10 U.S. gal**
 Final drive, each side.....11.0 ltr **2.9 U.S. gal**
 Swing drive.....20 ltr **5.3 U.S. gal**
 Hydraulic tank.....248 ltr **65.5 U.S. gal**
 Hydraulic system.....472 ltr **124.7 U.S. gal**



OPERATING WEIGHT (APPROXIMATE)

Operating weight without work tool (approximate)

Operating weight includes KO2US55 2-piece 16.8 m **55'** front, counterweight for MH 12317 kg **27,450 lb**, widen carbody, 78" cab riser, 25kw generator, rated capacities of lubricants, coolant, full fuel tank, operator and standard equipment.

Triple-Grouser Shoes	Operating Weight	Ground Pressure
700 mm 28"	57410 kg 126,530 lb	0.94 kg/cm ² 13.4 psi
800 mm 31.5"	57910 kg 127,630 lb	0.83 kg/cm ² 11.8 psi
900 mm 35.5"	58400 kg 128,710 lb	0.74 kg/cm ² 10.6 psi

For KOUS54 3-piece 16.5 m **54'** front, add weight 105 kg **230 lb**



DIMENSIONS

PC490LC-10 Material Handler			
A	Overall width across track shoes (crawler extended)	4395 mm	14' 5"
B	Overall width across track frame (crawler retracted)	3632 mm	11' 11"
C	Overall operating width including platform	4920 mm	16' 2"
D	Shoe width	900 mm	35.5"
E	Operating height to top of cab	5435 mm	17' 10"
F	Height to handrail	3530 mm	11' 7"
G	Height to counterweight	1385 mm	4' 7"
H	Ground clearance, minimum	737 mm	2' 5"
I	Tail swing radius	3645 mm	12' 0"
J	Track length on ground	4350 mm	14' 3"
K	Track length	5385 mm	17' 8"
L	Track gauge (crawler extended)	3505 mm	11' 6"
M	Grouser height	37 mm	1.5"
N	Machine cab height	3226 mm	10' 7"
O	Distance, swing center to rear end	3605 mm	11' 10"

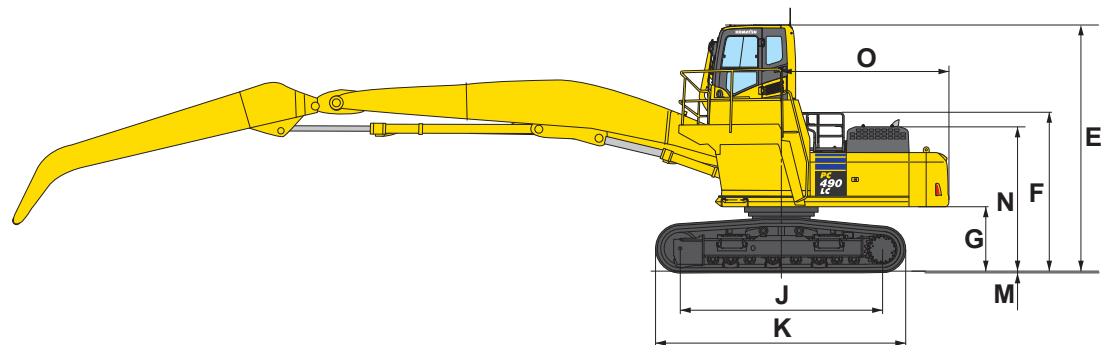
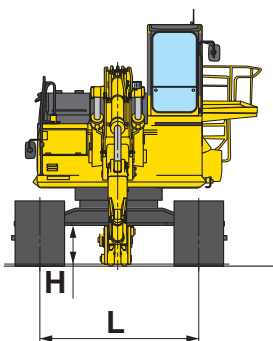
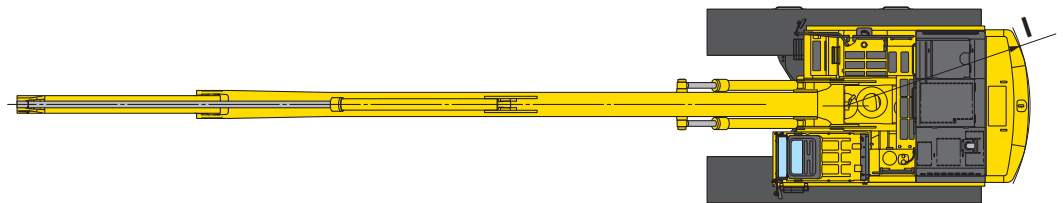
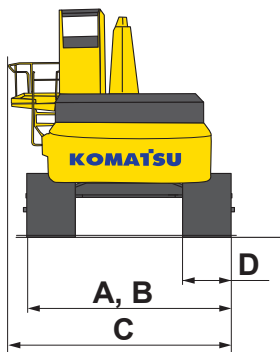



SHIPPING WEIGHTS AND DIMENSIONS (APPROXIMATE)

2-Piece Front KO2US55

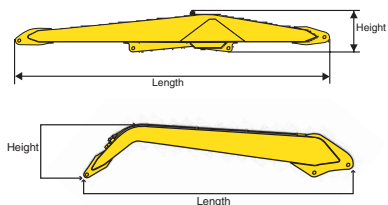

Model	KO2US55 16.8 m 55' front	
Description	Boom	Stick
Length	9527 mm 31'3"	7995 mm 26'3"
Width	1016 mm 3'4"	425 mm 1'5"
Height	1283 mm 4'2"	1512 mm 5'0"
Weight	5647 kg 12,450 lb	2336 kg 5,150 lb

3-Piece Front KOUS54

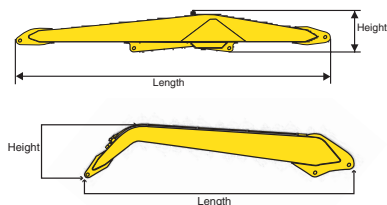

Model	KOUS54 16.5 m 54' front		
Description	Boom	Stick	JIB
Length	8052 mm 26'5"	4851 mm 15'11"	4394 mm 14'5"
Width	991 mm 3'3"	629 mm 2'1"	584 mm 1'11"
Height	1168 mm 3'10"	1067 mm 3'6"	813 mm 2'8"
Weight	4354 kg 9,600 lb	2086 kg 4,600 lb	1061 kg 2,339 lb

Cylinder Group

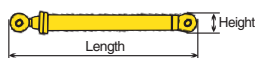

Model	KO2US55 16.8 m 55' front	
Description	Boom Cylinder	Stick Cylinder
Length	2718 mm 8'11"	3048 mm 10'0"
Width	457 mm 1'6"	533 mm 1'9"
Height	356 mm 1'2"	305 mm 1'0"
Weight	552 kg 1,150 lb	694 kg 1,531 lb

Cylinder Group

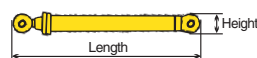

Model	KOUS54 16.5 m 54' front		
Description	Boom Cylinder	Stick Cylinder	JIB Cylinder
Length	2718 mm 8'11"	3023 mm 9'11"	2311 mm 7'7"
Width	457 mm 1'6"	584 mm 1'11"	356 mm 1'2"
Height	356 mm 1'2"	381 mm 1'3"	203 mm 0'8"
Weight	552 kg 1,150 lb	930 kg 2,050 lb	396 kg 874 lb

2-Piece Front Component Load

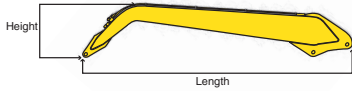

Model	KO2US55
16.8 m 55' front	
Description	Stick
Length	7989 mm 26'3"
Width	425 mm 1'5"
Height	1428 mm 4'9"
Weight	2336 kg 5,150 lb

Platform, Ladder, and Railing

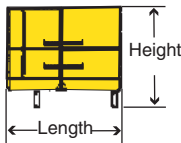

Model	Platform, Ladder, Railing
Description	
Length	1854 mm 6'1"
Width	1270 mm 4'2"
Height	1346 mm 4'5"
Weight	214 kg 471 lb

Counterweight

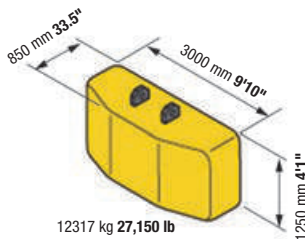

Shipping Configuration

Base Machine Equipped with:

- Main boom
- Boom cylinders
- Stick cylinders
- Counterweight removed
- 1981 mm 78" manual tilt cab riser
- 25 kW 34 HP generator package
- 900 mm 35.5" track shoes

Weight:

- 43186 kg 95,173 lb (KO2US55)
- 42125 kg 92,844 lb (KOUS54)

Overall Length:

- 12878 mm 507" (KO2US55)
- 11403 mm 449" (KOUS54)

Overall Height:

- 3658 mm 144"

Track Width:

- 3632 mm 11'11"

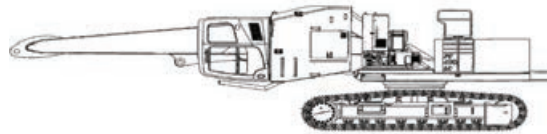

3-Piece Front Component Load

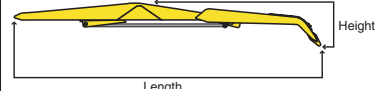

Model	KOUS54
16.5 m 54' front	
Description	Stick, Jib, Jib Cylinder
Length	8941 mm 29'4"
Width	629 mm 2'1"
Height	1067 mm 3'6"
Weight	3544 kg 7,813 lb

Platform, Ladder, and Railing

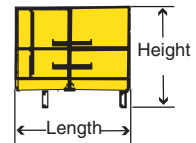

Model	Platform, Ladder, Railing
Description	
Length	1854 mm 6'1"
Width	1270 mm 4'2"
Height	1346 mm 4'5"
Weight	214 kg 471 lb

Counterweight

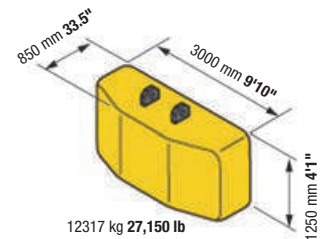



LIFTING CAPACITY

A: Reach from swing center
 B: Stick tip height
 C: Lifting capacity
 Cf: Rating over front
 Cs: Rating over side

Conditions:
 (In addition to PC490LC-10 base machine)
 • 2-piece front attachment with hydraulic cylinders
 • 1981 mm **78"** manual tilt cab riser with platform, stairs, and handrails
 • 5,049 psi working pressure
 • 177.8 mm **7.0"** diameter boom hoist cylinder

- 190.5 mm **7.5"** diameter stick cylinder
- LC variable gauge undercarriage
- 610 mm **24"** gauge widener
- 3500 mm **137.78"** gauge
- 700 mm **28"** track shoes
- 12,317 kg **27,150 lbs** counterweight
- 56,243 kg **123,994 lbs** total machine weight

Young 2-Piece Front (K02US55) - 16.8 m 55'

Unit: kg lb

B	A		3.0 m 10'		4.6 m 15'		6.1 m 20'		7.6 m 25'		9.1 m 30'		10.7 m 35'		12.2 m 40'		13.7 m 45'		15.2 m 50'		16.8 m 55'		
	Cf	Cs	Cf	Cs	Cf	Cs	Cf	Cs	Cf	Cs	Cf	Cs	Cf	Cs	Cf	Cs	Cf	Cs	Cf	Cs	Cf	Cs	
18.3 m 60'																							
16.8 m 55'									*10705	*10705													
15.2 m 50'																							
13.7 m 45'																							
12.2 m 40'																							
10.7 m 35'																							
9.1 m 30'																							
7.6 m 25'																							
6.1 m 20'																							
4.6 m 15'																							
3.0 m 10'																							
1.5 m 5'																							
0.0 m 0'																							
-1.5 m -5'																							
-3.0 m -10'																							
-4.6 m -15'																							
-6.1 m -20'																							
-7.6 m -25'																							
-9.1 m -30'																							

Note: Capacities are measured at the bare stick tip.
 Capacities marked with an asterisk (*) are limited by hydraulic capacities rather than stabilities.

1. Lifting capacities shown do not exceed 75% of minimum tipping loads or 87% of hydraulic capacities. Data supplied by Young Corp.
2. Lifting capacities shown should not be exceeded. Weight of all lifting accessories must be considered part of the load.
3. Lifting capacities assume the machine is standing level on a firm, uniform supporting surface. The user must make allowances for unfavorable job conditions such as soft or uneven ground or sudden stopping of loads.
4. The least stable position is over the side.
5. The operator should be fully acquainted with the Operation Manual before operating the machine.
6. Capacities apply only to the machine equipped as stated here.
7. Rated capacities are based on SAE-2518-1998 gross rated capacities.



LIFTING CAPACITY

A: Reach from swing center
B: Stick tip height
C: Lifting capacity
Cf: Rating over front
Cs: Rating over side

Conditions:
(In addition to PC490LC-10 base machine)

- 3-piece front attachment with hydraulic cylinders
- 1981 mm 78" manual tilt cab riser with platform, stairs, and handrails
- 5,049 psi working pressure
- 177.8 mm 7.0" diameter boom hoist cylinder
- 190.5 mm 7.5" diameter stick cylinder

- 165.1 mm 6.5" diameter jib cylinder
- LC variable gauge undercarriage
- 610 mm 24" gauge widener
- 3500 mm 137.78" gauge
- 700 mm 28" track shoes
- 12317 kg 27,150 lbs counterweight
- 56348 kg 124,226 lbs total machine weight

Young 3-Piece Front (KOUS54) - 16.5 m 54'

Unit: kg lb

B	A 3.0 m 10'		4.6 m 15'		6.1 m 20'		7.6 m 25'		9.1 m 30'		10.7 m 35'		12.2 m 40'		13.7 m 45'		15.2 m 50'		16.8 m 55'		
	Cf	Cs	Cf	Cs	Cf	Cs	Cf	Cs	Cf	Cs	Cf	Cs	Cf	Cs	Cf	Cs	Cf	Cs	Cf	Cs	
18.3 m 60'																					
16.8 m 55'					*12292	*12292	*11340	*11340													
15.2 m 50'									*11657	*11657	*10387	*10387									
13.7 m 45'													*11295	*11295	*11113	*11113	*9707	*9707			
12.2 m 40'													*12066	*12066	*11340	*11340	*10206	*10206	*9117	8074	
10.7 m 35'																					
9.1 m 30'																					
7.6 m 25'																					
6.1 m 20'																					
4.6 m 15'																					
3.0 m 10'																					
1.5 m 5'																					
0.0 m 0'																					
-1.5 m -5'																					
-3.0 m -10'																					
-4.6 m -15'																					
-6.1 m -20'																					
-7.6 m -25'																					
-9.1 m -30'																					

Note: Capacities are measured at the bare stick tip.
Capacities marked with an asterisk (*) are limited by hydraulic capacities rather than stabilities.

1. Lifting capacities shown do not exceed 75% of minimum tipping loads or 87% of hydraulic capacities. Data supplied by Young Corp.
2. Lifting capacities shown should not be exceeded. Weight of all lifting accessories must be considered part of the load.
3. Lifting capacities assume the machine is standing level on a firm, uniform supporting surface. The user must make allowances for unfavorable job conditions such as soft or uneven ground or sudden stopping of loads.
4. The least stable position is over the side.
5. The operator should be fully acquainted with the Operation Manual before operating the machine.
6. Capacities apply only to the machine equipped as stated here.
7. Rated capacities are based on SAE-2518-1998 gross rated capacities.



WORKING RANGE

Young 2-Piece Front — 16.8 m 55'
(K02US55)

Maximum Height — 18.1 m **59'6"**

Maximum Reach — 16.8 m **55'**

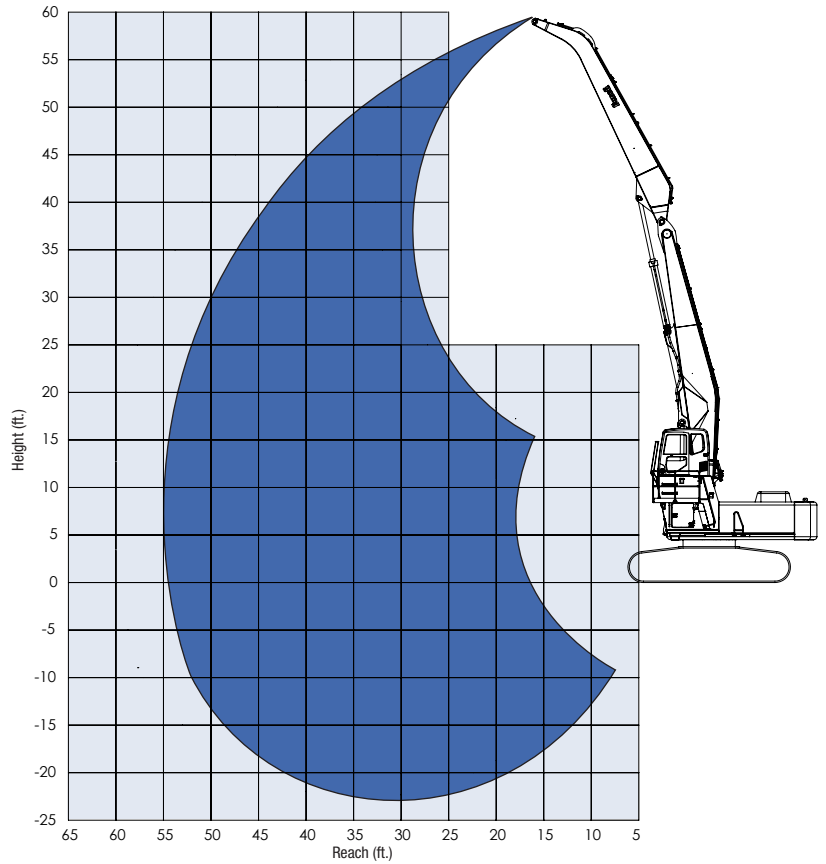

Young 3-Piece Front — 16.5 m 54'
(KOUS54)

Maximum Height — 18.0 m **59'**

Maximum Reach — 16.5 m **54'**

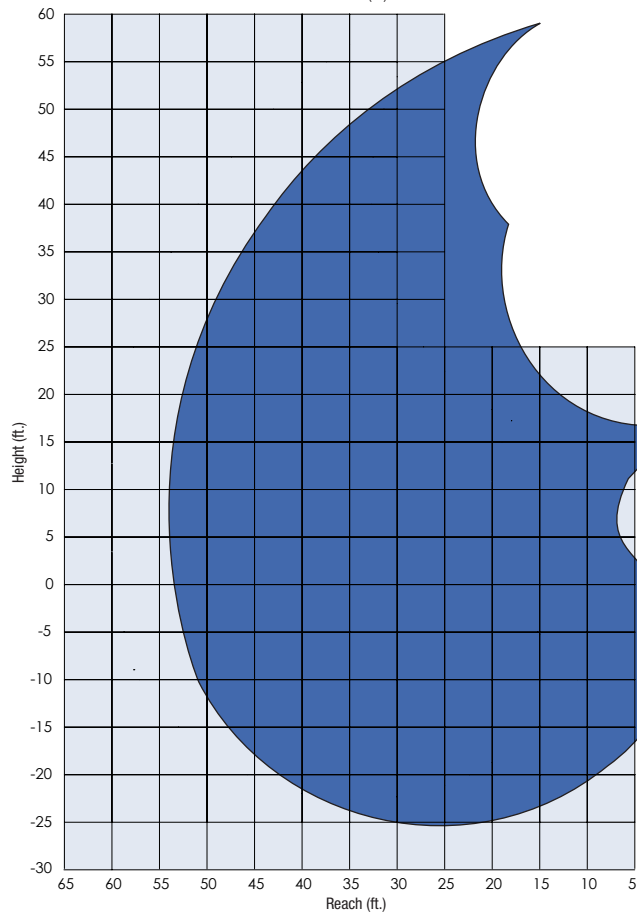

ATTACHMENTS

Grapple Selection Guide

Model	PC490LC-10	
	Young	
Recommended Grapple Model	LO-200B	LO-200B
	16.5 m 54' front	16.8 m 55' front
Size	1.5 m ³ 2.0 yd³	1.5 m ³ 2.0 yd³
Weight	2177 kg 4,800 lb	2177 kg 4,800 lb
A	2616 mm 103"	2616 mm 103"
B	2641 mm 104"	2641 mm 104"
C	3073 mm 121"	3073 mm 121"
D	1905 mm 75"	1905 mm 75"
E	210 mm 8.25"	210 mm 8.25"
F	76.2 mm 3.0"	76.2 mm 3.0"
G	2311 mm 91"	2311 mm 91"

Typical 4-Tine Grapple (Orange Peel)

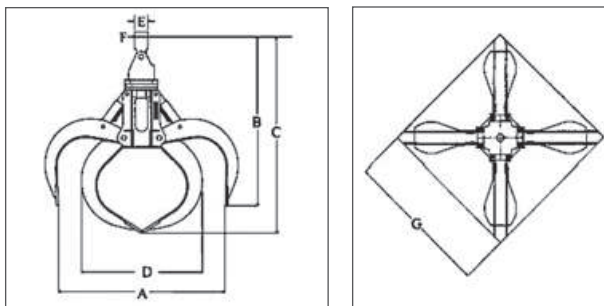

Grapple Applications:

Select a grapple whose weight including material does not exceed the lift capacity shown for your specific machine.

Note: Conditions and material densities vary. Confirm your specific load density before determining safe machine balance.

General Material Weights:

1. Steel scrap, clippings compressed or bundled weigh approximately 912 kg **2,025 lbs per yd³**.
2. Shredded steel scraps, unprepared, weigh approximately 608 kg **1,350 lbs per yd³**.

General Magnet Selection Guide

Magnet Size			Generator KW Rating	Approximate Magnet Operating Weight	Lifting Capacity						
Diameter	Max Cold Amps				A	B		C			
40"	1016 mm	30	T	816 kg	1,800 lb	408 kg	900 lb	272 kg	600 lb	170 kg	375 lb
45"	1143 mm	39	M	1270 kg	2,800 lb	816 kg	1,800 lb	499 kg	1,100 lb	283 kg	625 lb
48"	1219 mm	58	T	1315 kg	2,900 lb	794 kg	1,750 lb	426 kg	1,160 lb	272 kg	600 lb
57"	1447 mm	58	M	1860 kg	4,100 lb	1225 kg	2,700 lb	805 kg	1,775 lb	385 kg	850 lb
57"	1447 mm	80	T	1996 kg	4,400 lb	1225 kg	2,700 lb	816 kg	1,800 lb	385 kg	850 lb
66"	1676 mm	80	M	2812 kg	6,200 lb	1860 kg	4,100 lb	1247 kg	2,750 lb	612 kg	1,350 lb
66"	1676 mm	100	T	2903 kg	6,400 lb	1860 kg	4,100 lb	1247 kg	2,750 lb	612 kg	1,350 lb
72"	1828 mm	103	M	3719 kg	8,200 lb	2132 kg	4,700 lb	1429 kg	3,150 lb	680 kg	1,500 lb
72"	1828 mm	132	T	3765 kg	8,300 lb	2132 kg	4,700 lb	1429 kg	3,150 lb	680 kg	1,500 lb
78"	1981 mm	132	M	4445 kg	9,800 lb	2585 kg	5,700 lb	1776 kg	3,915 lb	844 kg	1,860 lb

T = Typical M = Maximum

Magnet Selection:

1. Select a magnet whose weight, including lifted material, does not exceed the lift capacity shown for your specific machine.
2. Select a magnet with a cold amp rating equal to or less than the figures shown in this chart.

Legend:

- A: Pig iron and #1 hot melt; refers in general to low iron content slag or slabs.
- B: #2 broken; scrap steel or cut offs.
- C: Steel turnings; scrap from machining processes.



STANDARD EQUIPMENT

- Alternator, 50 Ampere, 24V
- AM/FM radio
- Automatic engine warm-up system
- Automatic air conditioner/heater
- Auxiliary input (3.5mm jack)
- Batteries, large capacity
- Battery disconnect switch
- Boom and arm holding valves
- Converter, (2) x 12V
- Counterweight, 12317 kg **27,150 lb**
- Dry type air cleaner, double element
- Electric horn
- EMMS monitoring system
- Engine, Komatsu SAA6D125E-6-A
- Engine overheat prevention system
- Fan guard structure
- Fuel system pre-cleaner 10 micron
- High back air suspension seat, with heat

- Hydraulic cooling fan (reversible)
- Hydraulic track adjusters
- KOMTRAX® Level 4.0
- Large LCD color monitor, high resolution
- Lock lever
- Mirrors, (LH and RH)
- Operator Protective Top Guard (OPG), Level 1
- Pattern change valve (ISO to BH control)
- Power maximizing system
- PPC hydraulic control system
- Pump/engine room partition cover
- Radiator and oil cooler dustproof net
- Rear reflectors
- Rearview monitoring system (1 camera)
- Revolving frame deck guard
- Revolving frame undercovers
- ROPS cab

- Seat belt, retractable, 76 mm **3"**
- Seat belt indicator
- Secondary engine shutoff switch
- Service valve
- Shoes, triple grouser, 900mm **35.5"**
- Skylight
- Slip resistant foot plates
- Starter motor, 11.0kW/24V x 1
- Suction fan
- Thermal and fan guards
- Track frame undercover
- Travel alarm
- Two boom mode settings
- Widen carbody, retractable, 3505 mm **11'6"**, track gauge
- Working light (RH front)
- Working mode selection system



OPTIONAL EQUIPMENT

- (1) additional rearview camera
- 25 KW hydraulic driven generator (requires cab riser 1981 mm **78"** and main pump with aux drive)
- Cab guards
 - Full front guard, OPG Level 1**
 - Full front guard, OPG Level 2**
 - Bolt-on top guard, OPG Level 2
 - Lower front window guard**
- Cab riser 1981 mm **78"**, manual tilt, with cab front window guard

- Front:
 - 2-piece 16.8 m **55'** with piping and burst valves
 - 3-piece 16.5 m **54'** with piping and burst valves
- High pressure in-line hydraulic filters
- Hydraulic control packages for:
 - 2-piece front grapple only
 - 2-piece front grapple and magnet
 - 3-piece front grapple and magnet
- Hydraulic control unit, 1 actuator

- Komatsu main pump w/ aux drive (ILOS) (SAE B, 2 bolt flange, spline 13T 16/32DP)
- Rain visor
- Revolving frame undercovers, heavy duty
- Shoes, triple grouser, 800 mm **31.5"**
- Shoes, triple grouser, 700 mm **28"**
- Sun visor
- Straight travel pedal
- Track roller guards, full length
- Working light, front, one additional on cab

****Not available with cab riser**



ATTACHMENT OPTIONS

- 2 yd³ 4 tine scrap grapple
- Magnet mounting crosshead

For a complete list of available attachments, please contact your local Komatsu distributor.

The Young Corp attachments listed in this Spec Sheet have not been designed, tested or manufactured by Komatsu and we assume no responsibility for their performance. The attachment manufacturer (Young) is solely responsible for any failure, personal injury or property damage caused by the use of this equipment.

The attachment information was supplied by Young and its accuracy was not verified by Komatsu. The information is being provided for the convenience of Komatsu Distributors and customers as a general depiction and description of the attachment and its usage. The actual attachment may vary from the information included in this Spec Sheet. Please check with Young for the latest specifications.

Young is responsible for warranty on their products along with parts and service support. Distributors and customers should contact Young with questions or technical issues regarding the proper match of these attachments to their application.